

## CHAPTER 13 ALTERNATING CURRENTS

### 13.1 Alternating current in an inductance

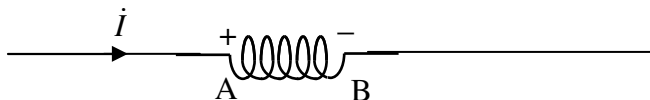

FIGURE XIII.1

In the figure we see a current increasing to the right and passing through an inductor. As a consequence of the inductance, a back EMF will be induced, with the signs as indicated. I denote the back EMF by  $V = V_A - V_B$ . The back EMF is given by  $V = L\dot{i}$ .

Now suppose that the current is an alternating current given by

$$I = \hat{I} \sin \omega t. \quad 13.1.1$$

In that case  $\dot{i} = \hat{I}\omega \cos \omega t$ , and therefore the back EMF is

$$V = \hat{I}L\omega \cos \omega t, \quad 13.1.2$$

which can be written 
$$V = \hat{V} \cos \omega t, \quad 13.1.3$$

where the peak voltage is 
$$\hat{V} = L\omega \hat{I} \quad 13.1.4$$

and, of course  $V_{\text{RMS}} = L\omega I_{\text{RMS}}$ . (See Section 13.11.)

The quantity  $L\omega$  is called the *inductive reactance*  $X_L$ . It is expressed in ohms (check the dimensions), and, the higher the frequency, the greater the reactance. (The frequency  $\nu$  is  $\omega/(2\pi)$ .)

Comparison of equations 13.1.1 and 13.1.3 shows that the current and voltage are out of phase, and that  $V$  leads on  $I$  by  $90^\circ$ , as shown in figure XIII.2.

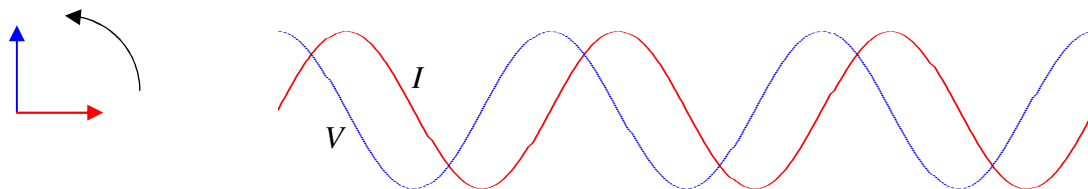

FIGURE XIII.2

## 13.2 Alternating Voltage across a Capacitor

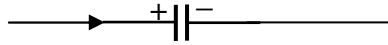

FIGURE XIII.3

At any time, the charge  $Q$  on the capacitor is related to the potential difference  $V$  across it by  $Q = CV$ . If there is a current in the circuit, then  $Q$  is changing, and  $I = C\dot{V}$ .

Now suppose that an alternating voltage given by

$$V = \hat{V} \sin \omega t \quad 13.2.1$$

is applied across the capacitor.

In that case the current is 
$$I = C\omega\hat{V} \cos \omega t, \quad 13.2.2$$

which can be written 
$$I = \hat{I} \cos \omega t, \quad 13.2.3$$

where the peak current is 
$$\hat{I} = C\omega\hat{V} \quad 13.2.4$$

and, of course  $I_{\text{RMS}} = C\omega V_{\text{RMS}}$ .

The quantity  $1/(C\omega)$  is called the *capacitive reactance*  $X_C$ . It is expressed in ohms (check the dimensions), and, the higher the frequency, the smaller the reactance. (The frequency  $\nu$  is  $\omega/(2\pi)$ .)

[When we come to deal with complex numbers, in the next and future sections, we shall incorporate a sign into the reactance. We shall call the reactance of a capacitor  $-1/(C\omega)$  rather than merely  $1/(C\omega)$ , and the minus sign will indicate to us that  $V$  lags behind  $I$ . The reactance of an inductor will remain  $L\omega$ , since  $V$  leads on  $I$ .]

Comparison of equations 13.2.1 and 13.2.3 shows that the current and voltage are out of phase, and that  $V$  lags behind  $I$  by  $90^\circ$ , as shown in figure XIII.4.

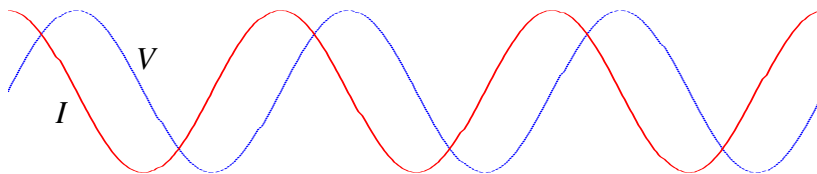

FIGURE XIII.4

### 13.3 Complex Numbers

I am now going to repeat the analyses of Sections 13.1 and 13.2 using the notation of complex numbers. In the context of alternating current theory, the imaginary unit is customarily given the symbol  $j$  rather than  $i$ , so that the symbol  $i$  is available, if need be, for electric currents. I am making the assumption that the reader is familiar with the basics of complex numbers; without that background, the reader may have difficulty with much of this chapter.

We start with the inductance. If the current is changing, there will be a back EMF given by  $V = L\dot{I}$ . If the current is changing as

$$I = \hat{I}e^{j\omega t}, \quad 13.3.1$$

then  $\dot{I} = \hat{I}j\omega e^{j\omega t} = j\omega I$ . Therefore the voltage is given by

$$V = jL\omega I. \quad 13.3.2$$

The quantity  $jL\omega$  is called the *impedance* of the inductor, and is  $j$  times its *reactance*. Its *reactance* is  $L\omega$ , and, in SI units, is expressed in ohms. Equation 13.3.2 (in particular the operator  $j$  on the right hand side) tells us that  $V$  leads on  $I$  by  $90^\circ$ .

Now suppose that an alternating voltage is applied across a capacitor. The charge on the capacitor at any time is  $Q = CV$ , and the current is  $I = C\dot{V}$ . If the voltage is changing as

$$V = \hat{V}e^{j\omega t}, \quad 13.3.3$$

then  $\dot{V} = \hat{V}j\omega e^{j\omega t} = j\omega V$ . Therefore the current is given by

$$I = jC\omega V. \quad 13.3.4$$

That is to say 
$$V = -\frac{j}{C\omega} I. \quad 13.3.5$$

The quantity  $-j/(C\omega)$  is called the *impedance* of the capacitor, and is  $j$  times its reactance. Its reactance is  $-1/(C\omega)$ , and, in SI units, is expressed in ohms. Equation 13.3.5 (in particular the operator  $-j$  on the right hand side) tells us that  $V$  lags behind  $I$  by  $90^\circ$ .

In summary:

Inductor: Reactance =  $L\omega$ .      Impedance =  $jL\omega$ .       $V$  leads on  $I$ .

Capacitor: Reactance =  $-1/(C\omega)$       Impedance =  $-j/(C\omega)$ .       $V$  lags behind  $I$ .

It may be that at this stage you haven't got a very clear idea of the distinction between reactance (symbol  $X$ ) and impedance (symbol  $Z$ ) other than that one seems to be  $j$  times the other. The next section deals with a slightly more complicated situation, namely a resistor and an inductor in series. (In practice, it may be one piece of equipment, such as a solenoid, that has both resistance and inductance.) Paradoxically, you may find it easier to understand the distinction between impedance and reactance from this more complicated situation.

#### 13.4 Resistance and Inductance in Series

The impedance is just the sum of the resistance of the resistor and the impedance of the inductor:

$$Z = R + jL\omega. \quad 13.4.1$$

Thus the impedance is a *complex number*, whose real part  $R$  is the resistance and whose imaginary part  $L\omega$  is the reactance. For a pure resistance, the impedance is real, and  $V$  and  $I$  are in phase. For a pure inductance, the impedance is imaginary (reactive), and there is a  $90^\circ$  phase difference between  $V$  and  $I$ .

The voltage and current are related by

$$V = IZ = (R + jL\omega)I. \quad 13.4.2$$

Those who are familiar with complex numbers will see that this means that  $V$  leads on  $I$ , not by  $90^\circ$ , but by the *argument* of the complex impedance, namely  $\tan^{-1}(L\omega/R)$ . Further the ratio of the peak (or RMS) voltage to the peak (or RMS) current is equal to the *modulus* of the impedance, namely  $\sqrt{R^2 + L^2\omega^2}$ .

#### 13.5 Resistance and Capacitance in Series

Likewise the impedance of a resistance and a capacitance in series is

$$Z = R - j/(C\omega). \quad 13.5.1$$

The voltage and current are related, as usual, by  $V = IZ$ . Equation 13.5.1 shows that the voltage lags behind the current by  $\tan^{-1}[1/(RC\omega)]$ , and that  $\hat{V}/\hat{I} = \sqrt{R^2 + 1/(C\omega)^2}$ .

#### 13.6 Admittance

In general, the impedance of a circuit is partly resistive and partly reactive:

$$Z = R + jX. \quad 13.6.1$$

The real part is the resistance, and the imaginary part is the reactance. The relation between  $V$  and  $I$  is  $V = IZ$ . If the circuit is purely resistive,  $V$  and  $I$  are in phase. If it is purely reactive,  $V$  and  $I$  differ in phase by  $90^\circ$ . The reactance may be partly inductive and partly capacitive, so that

$$Z = R + j(X_L + X_C). \quad 13.6.2$$

Indeed we shall describe such a system in detail in the next section. Note that  $X_C$  is *negative*.

[The equation is sometimes written  $Z = R + j(X_L - X_C)$ , in which  $X_C$  is intended to represent the unsigned quantity  $1/(C\omega)$ . In these notes  $X_C$  is intended to represent  $-1/(C\omega)$ .]

The reciprocal of the impedance  $Z$  is the *admittance*,  $Y$ .

Thus

$$Y = \frac{1}{Z} = \frac{1}{R + jX}. \quad 13.6.3$$

And of course, since  $V = IZ$ ,  $I = VY$ .

Whenever we see a complex (or a purely imaginary) number in the denominator of an expression, we always immediately multiply top and bottom by the complex conjugate, so equation 13.6.3 becomes

$$Y = \frac{Z^*}{|Z|^2} = \frac{R - jX}{R^2 + X^2}. \quad 13.6.4$$

This can be written

$$Y = G + jB, \quad 13.6.5$$

where the real part,  $G$ , is the *conductance*:

$$G = \frac{R}{R^2 + X^2}, \quad 13.6.6$$

and the imaginary part,  $B$ , is the *susceptance*:

$$B = -\frac{X}{R^2 + X^2}. \quad 13.6.7$$

The SI unit for admittance, conductance and susceptance is the *siemens* (or the "mho" in informal talk).

I leave it to the reader to show that

$$R = \frac{G}{G^2 + B^2} \quad 13.6.8$$

and

$$X = -\frac{B}{G^2 + B^2}. \quad 13.6.9$$

*Example*

What is the impedance of the circuit below to alternating current of frequency  $2000/\pi$  Hz ( $\omega = 4000$  rad s<sup>-1</sup>)?

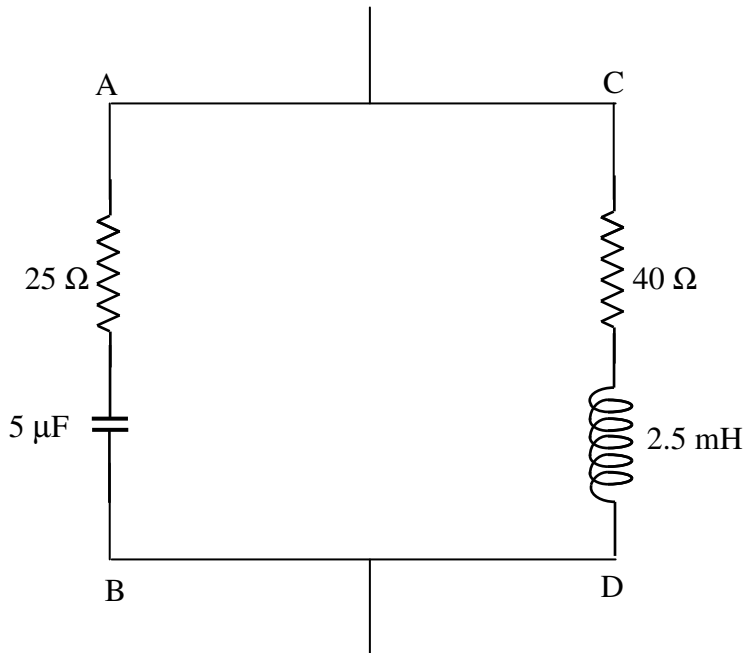

I think that the following will be readily agreed. (Remember, the admittance is the reciprocal of the impedance; and, whenever you see a complex number in a denominator, immediately multiply top and bottom by the conjugate.)

$$\text{Impedance of AB} = (25 - 50j) \ \Omega$$

$$\text{Impedance of CD} = (40 + 10j) \ \Omega$$

$$\text{Admittance of AB} = \frac{1 + 2j}{125} \ \text{S} = \frac{6 + 12j}{750} \ \text{S}$$

$$\text{Admittance of CD} = \frac{4 - j}{150} \ \text{S} = \frac{20 - 5j}{750} \ \text{S}$$

$$\text{Admittance of the circuit} = \frac{26 + 7j}{750} \text{ S}$$

$$\text{Impedance of the circuit} = \frac{30(26 - 7j)}{29} \Omega$$

The current leads on the voltage by  $15^\circ$

*Another example*

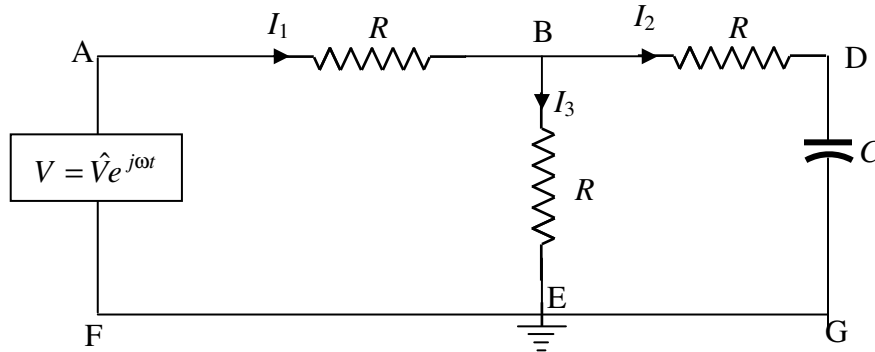

Three resistors and a capacitor are connected to an AC voltage source as shown. The point E is grounded (earthed), and its potential can be taken as zero. Calculate the three currents, and the potential at B.

We can do this by using Kirchhoff's rules in the usual way. When I did this I found the algebra to be slightly heavy going, and I found that it was much simplified by writing  $\frac{1}{C\omega} = aR$ , where  $a$  is a dimensionless number. Then, instead of writing the impedance of the section BDG as  $R - \frac{j}{C\omega}$ , I write it as  $R(1 - ja)$ .

Kirchhoff's rules, applied to two circuits and the point B, are

$$V = I_1 R + I_2 R \quad 13.6.10$$

$$I_2(1 - ja) - I_3 = 0 \quad 13.6.11$$

$$I_1 = I_2 + I_3 \quad 13.6.12$$

These equations are to be solved for the three currents  $I_1, I_2, I_3$ . These will all be complex numbers, representing alternating currents. Solution could proceed, for example, by eliminating  $I_3$  from equations (10) and (11), and then eliminating  $I_3$  from equations (10) and (12). This results in two equations in  $I_1$  and  $I_2$ . We can eliminate  $I_1$  from these to obtain  $I_2$ . I make it  $I_2 = \frac{V}{R(3 - 2aj)}$ ,

but then we immediately multiply top and bottom by  $3 + 2aj$  to obtain

$$I_2 = \left( \frac{3 + 2aj}{9 + 4a^2} \right) \frac{V}{R} \quad 13.6.13$$

It is then straightforward to return to the original equations to obtain

$$I_1 = \left( \frac{6 + 2a^2 + aj}{9 + 4a^2} \right) \frac{V}{R} \quad 13.6.14$$

and

$$I_3 = \left( \frac{3 + 2a^2 - aj}{9 + 4a^2} \right) \frac{V}{R} \quad 13.6.15$$

For example, suppose that the frequency and the capacitance were such that  $a = 1$ , then

$$I_1 = \left( \frac{8 + j}{13} \right) \frac{V}{R} \quad 13.6.16$$

$$I_2 = \left( \frac{3 + 2j}{13} \right) \frac{V}{R} \quad 13.6.17$$

and

$$I_3 = \left( \frac{5 - j}{13} \right) \frac{V}{R} \quad 13.6.18$$

Thus  $I_1$  leads on  $V$  by  $7^\circ.1$ ;  $I_2$  leads on  $V$  by  $33^\circ.7$ ; and  $I_3$  lags behind  $V$  by  $11^\circ.3$ .

The vector (phasor) diagram for these three currents is shown below, in which the phasor representing the alternating voltage  $V$  is directed along the real axis.

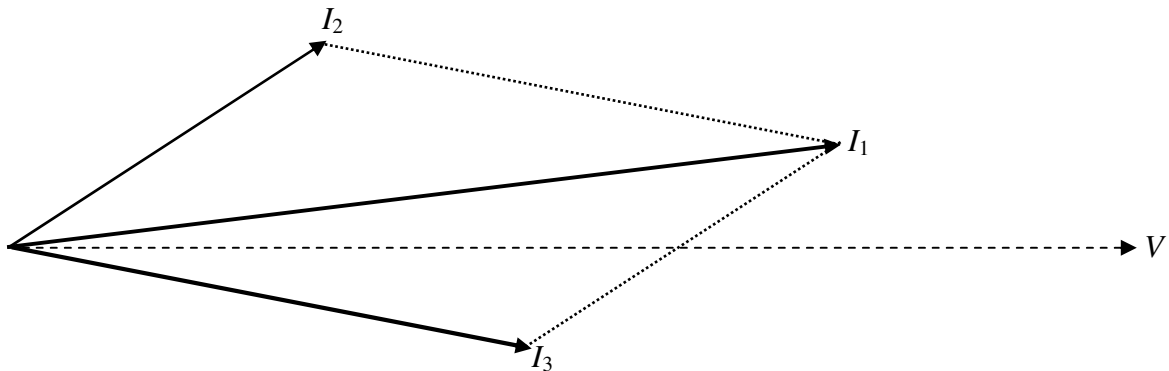



Bearing in mind that the potential at E is zero, we see that the potential at B is just  $I_3R$  and is in phase with  $I_3$ .

There is another method of finding  $I_1$ , which we now try. If we get the same answer by both methods, this will be a nice check for possible mistakes in the algebra.

I'll re-draw the circuit diagram as follows:

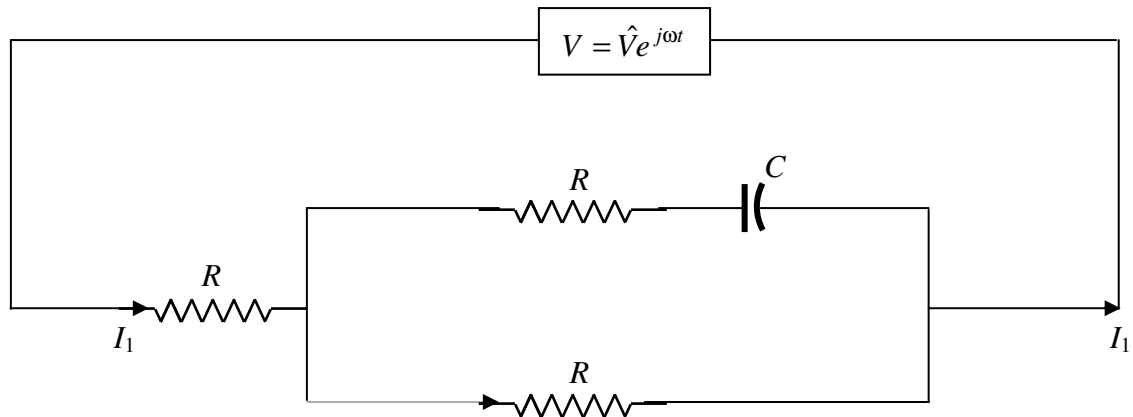

To calculate  $I_1$  we have to calculate the admittance  $Y$  of the circuit, and then we have immediately  $I_2 = YV$ . The impedance of  $R$  and  $C$  in series is  $R - jaR$  and so its admittance is

$\frac{1}{R - jaR}$ . The admittance of the rectangle is therefore  $\frac{1}{R - jaR} + \frac{1}{R} = \frac{1}{R} \left[ \frac{2 - ja}{1 - ja} \right]$ . The

impedance of the rectangle is  $R \left[ \frac{1 - ja}{2 - ja} \right]$ , and the impedance of the whole circuit is  $R$  plus this,

which is  $R \left[ \frac{3 - 2ja}{2 - ja} \right]$ . The admittance of the whole circuit is  $\frac{1}{R} \left[ \frac{2 - ja}{3 - 2ja} \right]$ . Multiply top and

bottom by the conjugate of the denominator to obtain  $\frac{1}{R} \left[ \frac{6 + 2a^2 + ja}{9 + 4a^2} \right]$ . Hence

$I_1 = \frac{V}{R} \left[ \frac{6 + 2a^2 + ja}{9 + 4a^2} \right]$ , which is what we obtained by the Kirchoff method.

If you want to invent some similar problems, either as a student for practice, or as an instructor looking for homework or examination questions, you could generalize the above problem as follows.

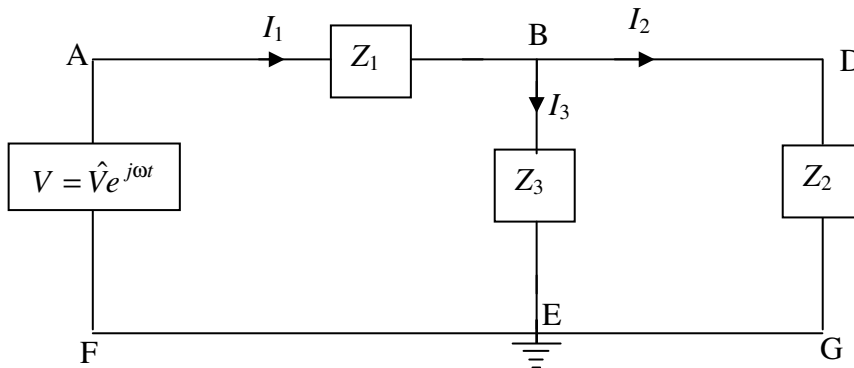

Each of the three impedances in the circuit could be various combinations of capacitors and inductors in series or in parallel, but, whatever the configuration, each could be written in the form  $R + jX$ . Three Kirchhoff equations could be constructed as follows

$$V = I_1 Z_1 + I_3 Z_3 \quad 13.6.19$$

$$V = I_1 Z_1 + I_2 Z_2 \quad 13.6.20$$

$$I_1 = I_2 + I_3 \quad 13.6.21$$

If I have done my algebra correctly, I make the solutions

$$I_1 = \frac{V(Z_2 + Z_3)}{Z_2 Z_3 + Z_3 Z_1 + Z_1 Z_2} \quad 13.6.22$$

$$I_2 = \frac{V Z_3}{Z_2 Z_3 + Z_3 Z_1 + Z_1 Z_2} \quad 13.6.23$$

$$I_3 = \frac{V Z_2}{Z_2 Z_3 + Z_3 Z_1 + Z_1 Z_2} \quad 13.6.24$$

Each must eventually be written in the form  $\text{Re } I + j \text{Im } I$ , or  $(G + jB)V$ . For example, suppose that the three impedances, in ohms, are  $Z_1 = 2 - 3j$ ,  $Z_2 = 4 + 2j$ ,  $Z_3 = 3 - 3j$ . In that case, I believe (let me know if I'm wrong, jtatam at uvic.ca) that equation 13.6.25 becomes, after manipulation,  $I_3 = \frac{74 + 152j}{1429} V$ . This means that  $I_3$  leads on  $V$  by  $64^\circ.0$ , and that the peak value of  $I_3$  is  $0.118V$  A, where  $V$  is in V.

The potential at B is  $I_3 Z_3$ . Both of these are complex numbers and the potential at B is not in phase with  $I_3$  unless  $Z_3$  is purely resistive.

In composing a problem, you probably want all resistances and reactances to be of comparable magnitudes, say a few ohms each. As a guide, if you choose the frequency to be  $500/\pi$  Hz, so that  $\omega = 10^3 \text{ rad s}^{-1}$ , and if you choose inductances to be about 10 mH and capacitances about 100  $\mu\text{F}$ , your reactances will each be about 10  $\Omega$ .

You can probably also compose problems with various bridge circuits, such as

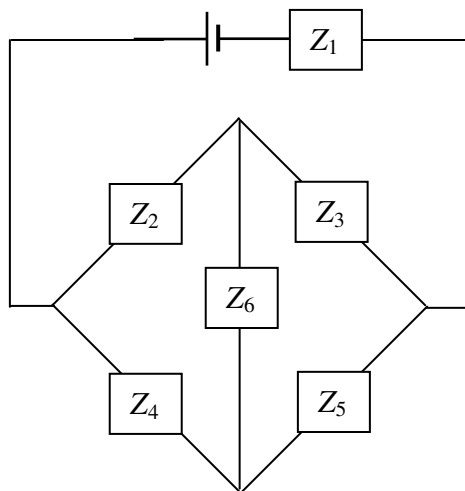

There are six independent impedances, so you'll need six equations. Three for Kirchhoff's second rule, to cover the complete circuit once; and three of Kirchhoff's first rule, at three points. Good luck in solving them. Remember that, in an equation involving complex numbers, the real and imaginary parts are separately equal. And remember, as soon as a complex number appears in a denominator, multiply top and bottom by the conjugate. Alternatively, and easier, we could do what we did with a similar problem with direct currents in Section 4.12, using a delta-star transformation. We'll try an example in Section 13.9, subsection 13.9.4, and we make some further remarks on the delta-star transform with alternating currents in Section 13.12.

### 13.7 The RLC Series Acceptor Circuit

A resistance, inductance and a capacitance in series is called an "acceptor" circuit, presumably because, for some combination of the parameters, the magnitude of the inductance is a minimum, and so current is accepted most readily. We see in figure XIII.5 an alternating voltage  $V = \hat{V}e^{j\omega t}$  applied across such an  $R$ ,  $L$  and  $C$ .

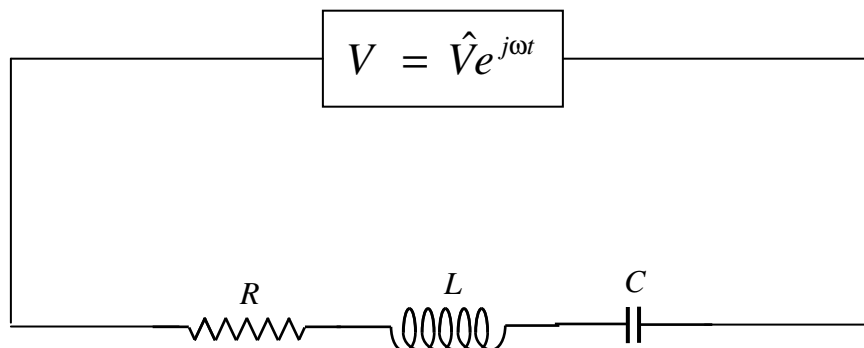

FIGURE XIII.5

The impedance is

$$Z = R + j\left(L\omega - \frac{1}{C\omega}\right) \quad 13.7.1$$

We can see that the voltage leads on the current if the reactance is positive; that is, if the inductive reactance is greater than the capacitive reactance; that is, if  $\omega > 1/\sqrt{LC}$ . (Recall that the frequency,  $\nu$ , is  $\omega/(2\pi)$ ). If  $\omega < 1/\sqrt{LC}$ , the voltage lags behind the current. And if  $\omega = 1/\sqrt{LC}$ , the circuit is purely resistive, and voltage and current are in phase.

The magnitude of the impedance (which is equal to  $\hat{V}/\hat{I}$ ) is

$$|Z| = \sqrt{R^2 + (L\omega - 1/(C\omega))^2}, \quad 13.7.2$$

and this is least (and hence the current is greatest) when  $\omega = 1/\sqrt{LC}$ , the resonant frequency, which I shall denote by  $\omega_0$ .

It is of interest to draw a graph of how the magnitude of the impedance varies with frequency for various values of the circuit parameters. I can reduce the number of parameters by defining the dimensionless quantities

$$\Omega = \omega / \omega_0 \quad 13.7.3$$

$$Q = \frac{1}{R} \sqrt{\frac{L}{C}} \quad 13.7.4$$

and

$$z = \frac{|Z|}{R}. \quad 13.7.4$$

You should verify that  $Q$  is indeed dimensionless. We shall see that the sharpness of the resonance depends on  $Q$ , which is known as the *quality factor* (hence the symbol  $Q$ ). In terms of the dimensionless parameters, equation 13.7.2 becomes

$$z = \sqrt{1 + Q^2(\Omega - 1/\Omega)^2}. \quad 13.7.5$$

This is shown in figure XIII.6, in which it can be seen that the higher the quality factor, the sharper the resonance.

FIGURE XIII.6

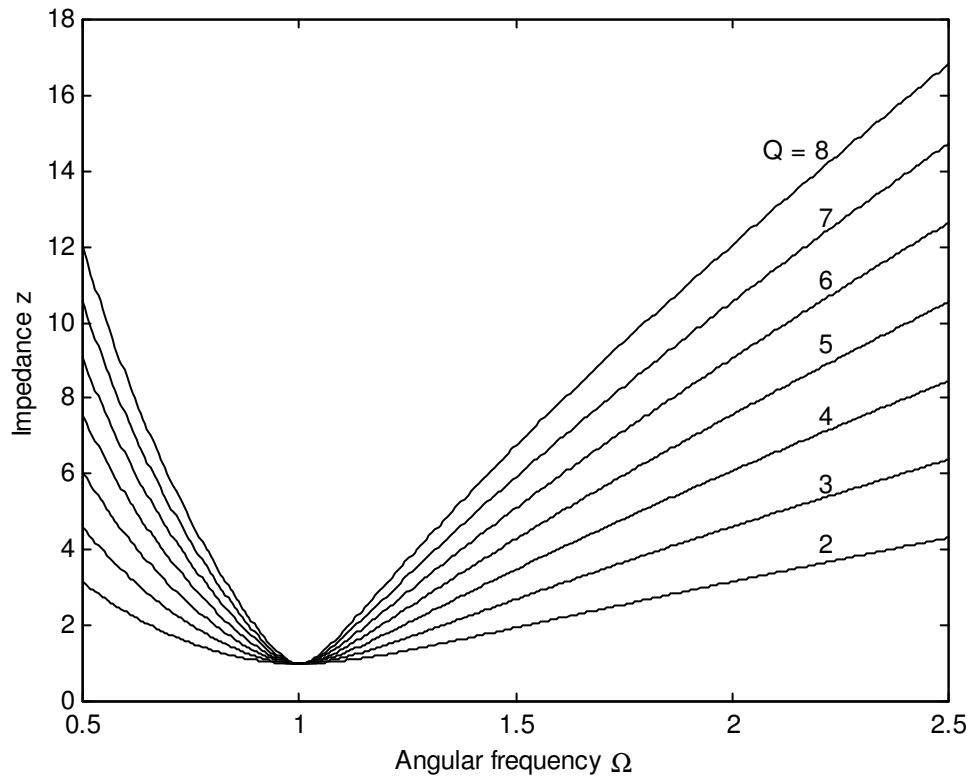

In particular, it is easy to show that the frequencies at which the impedance is twice its minimum value are given by the positive solutions of

$$\Omega^4 - \left(2 + \frac{3}{Q^2}\right)\Omega^2 + 1 = 0. \quad 13.7.6$$

If I denote the smaller and larger of these solutions by  $\Omega_-$  and  $\Omega_+$ , then  $\Omega_+ - \Omega_-$  will serve as a useful description of the width of the resonance, and this is shown as a function of quality factor in figure XIII.7.

FIGURE XIII.7

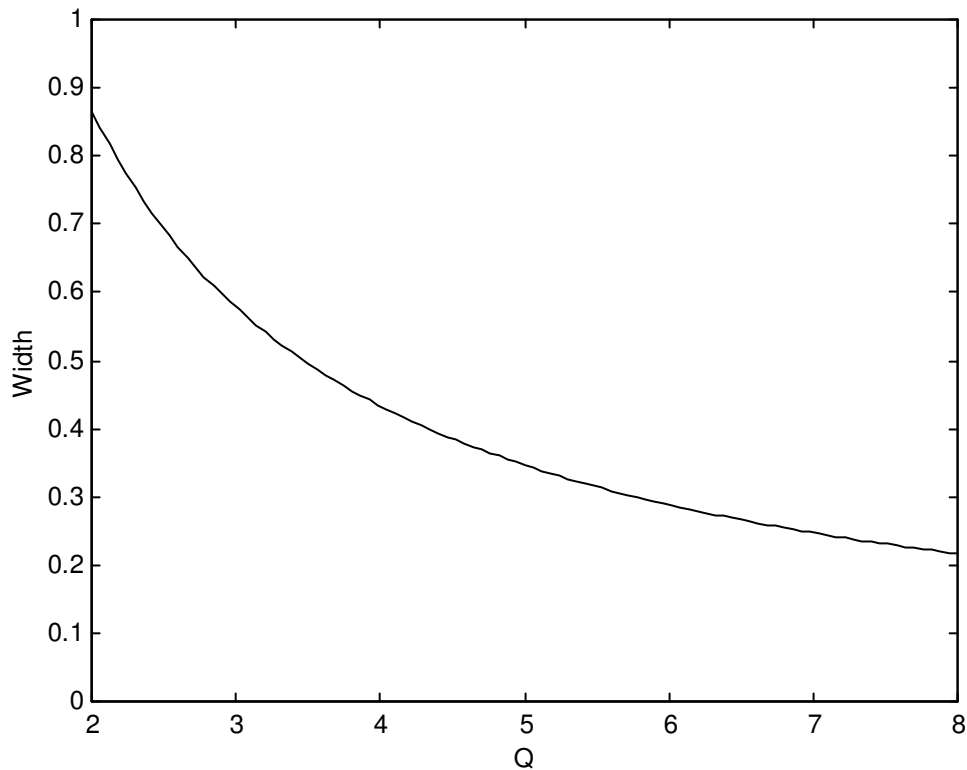

### 13.8 The RLC Parallel Rejctor Circuit

In the circuit below, the magnitude of the *admittance* is least for certain values of the parameters. When you tune a radio set, you are changing the overlap area (and hence the capacitance) of the plates of a variable air-spaced capacitor so that the admittance is a minimum for a given frequency, so as to ensure the highest potential difference across the circuit. This resonance, as we shall see, does not occur for an angular frequency of exactly  $1/\sqrt{LC}$ , but at an angular frequency that is approximately this if the resistance is small.

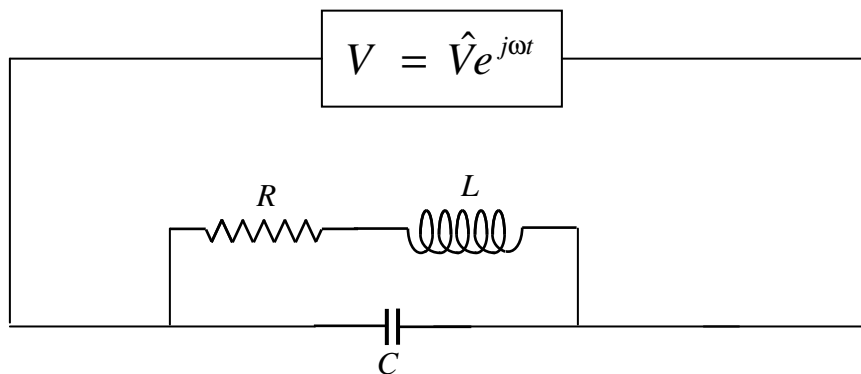

The admittance is

$$Y = jC\omega + \frac{1}{R + jL\omega} . \quad 13.8.1$$

After some routine algebra (multiply top and bottom by the conjugate; then collect real and imaginary parts), this becomes

$$Y = \frac{R + j\omega(L^2C\omega^2 + R^2C - L)}{R^2 + L^2\omega^2} . \quad 13.8.2$$

The magnitude of the admittance is least when the susceptance is zero, which occurs at an angular frequency of

$$\omega_0^2 = \frac{1}{LC} - \frac{R^2}{L^2} . \quad 13.8.3$$

If  $R \ll \sqrt{L/C}$ , this is approximately  $1/\sqrt{LC}$ .

### 13.9 AC Bridges

We have already met, in Chapter 4, Section 4.11, the Wheatstone bridge, which is a DC (direct current) bridge for comparing resistances, or for "measuring" an unknown resistance if it is compared with a known resistance. In the Wheatstone bridge (figure IV.9), balance is achieved when  $\frac{R_1}{R_2} = \frac{R_3}{R_4}$ . Likewise in a AC (alternating current) bridge, in which the power supply is an AC generator, and there are impedances (combinations of  $R$ ,  $L$  and  $C$ ) in each arm (figure XIII.8),

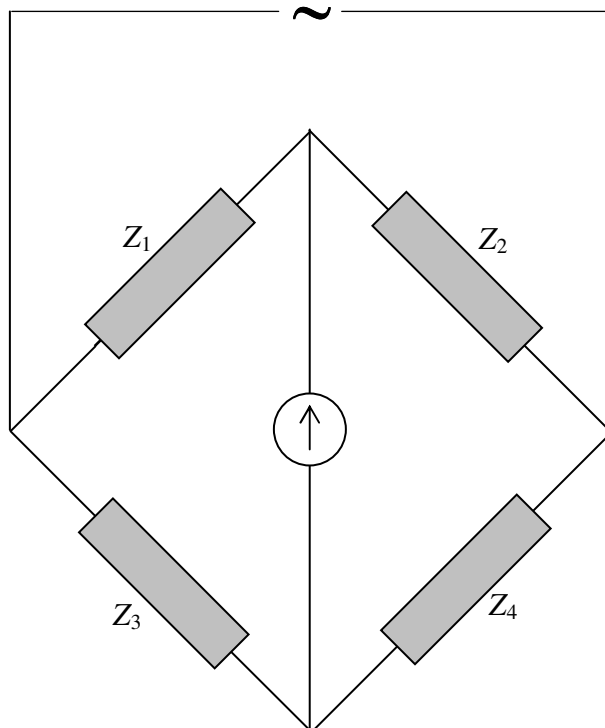

FIGURE XIII.8

balance is achieved when

$$\frac{Z_1}{Z_2} = \frac{Z_3}{Z_4} \quad 13.9.1$$

or, of course,  $\frac{Z_1}{Z_3} = \frac{Z_2}{Z_4}$ . This means not only that the RMS potentials on both sides of the detector must be equal, but they must be *in phase*, so that the potentials are the same *at all times*. (I have drawn the "detector" as though it were a galvanometer, simply because that is easiest for me to draw. In practice, it might be a pair of earphones or an oscilloscope.) Each side of equation 13.9.1 is a complex number, and two complex numbers are equal if and only if their real and imaginary parts are separately equal. Thus equation 13.9.1 really represents two equations – which are necessary in order to satisfy the two conditions that the potentials on either side of the detector are equal in magnitude and in phase.

We shall look at three examples of AC bridges. It is not recommended that these be committed to memory. They are described only as examples of how to do the calculation.

### 13.9.1 *The Owen Bridge*

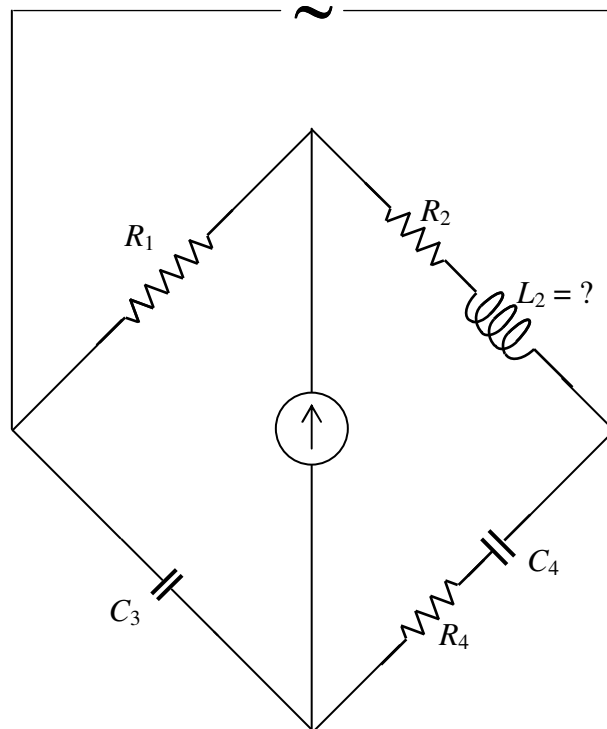

FIGURE XIII.9



This bridge can be used for measuring inductance. Note that the unknown inductance is the only inductance in the bridge. Reactance is supplied by the capacitors.

Equation 13.9.1 in this case becomes

$$\frac{R_1}{R_2 + jL_2\omega} = \frac{-j/(C_3\omega)}{R_4 - j/(C_4\omega)}. \quad 13.9.2$$

That is, 
$$R_1R_4 - j\frac{R_1}{C_4\omega} = \frac{L_2}{C_3} - j\frac{R_2}{C_3\omega}. \quad 13.9.3$$

On equating real and imaginary parts separately, we obtain

$$L_2 = R_1R_4C_3 \quad 13.9.4$$

and 
$$\frac{R_1}{R_2} = \frac{C_4}{C_3}. \quad 13.9.5$$

### 13.9.2 The Schering Bridge

This bridge can be used for measuring capacitance.

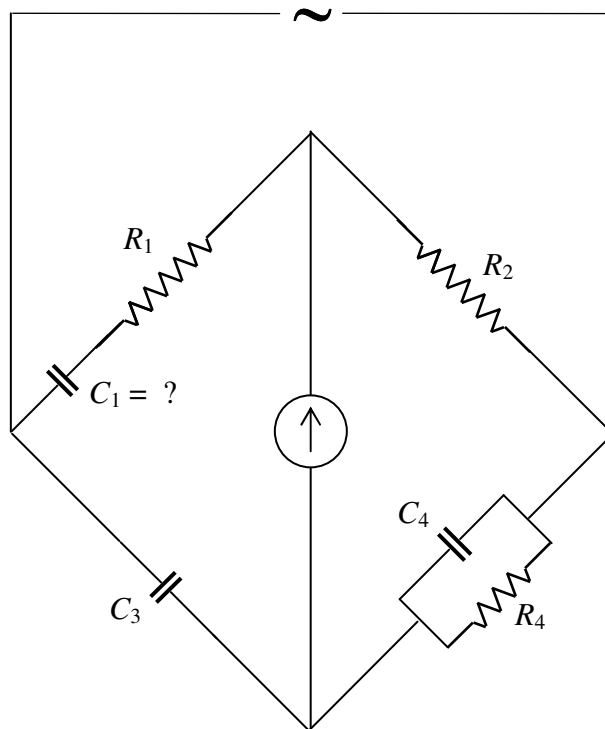

FIGURE XIII.10

The admittance of the fourth arm is  $\frac{1}{R_4} + jC_4\omega$ , and its impedance is the reciprocal of this. I leave the reader to balance the bridge and to show that

$$\frac{R_1}{R_2} = \frac{C_4}{C_3} \quad 13.9.6$$

and

$$C_1 = \frac{C_3 R_4}{R_2}. \quad 13.9.7$$

### 13 9.3 The Wien Bridge

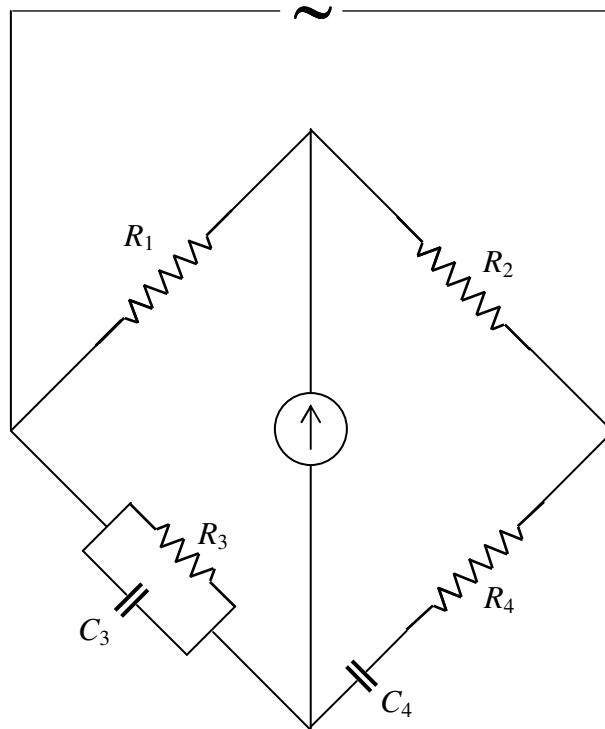

FIGURE XIII.11

This bridge can be used for measuring frequency.

The reader will, I think, be able to show that

$$\frac{R_4}{R_3} + \frac{C_3}{C_4} = \frac{R_2}{R_1} \quad 13.9.8$$

and

$$\omega^2 = \frac{1}{R_3 R_4 C_3 C_4} \quad 13.9.10$$

#### 13.9.4 Bridge Solution by Delta-Star Transform

In the above examples, we have calculated the condition that there is no current in the detector - i.e. that the bridge is balanced. Such calculations are relatively easy. But what if the bridge is not balanced? Can we calculate the impedance of the circuit? Can we calculate the currents in each branch, or the potentials at any points? This is evidently a little harder. We should be able to do it. Kirchhoff's rules and the delta-star transform still apply for alternating currents, the complication being that all impedances, currents and potentials are complex numbers.

Let us start by trying the following problem:

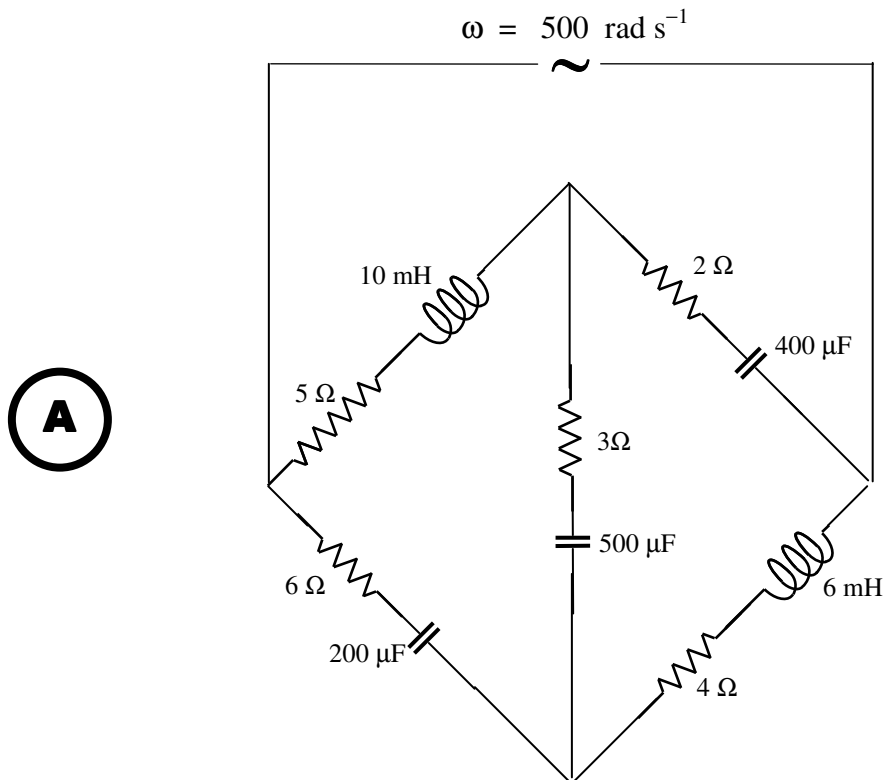

That is to say:

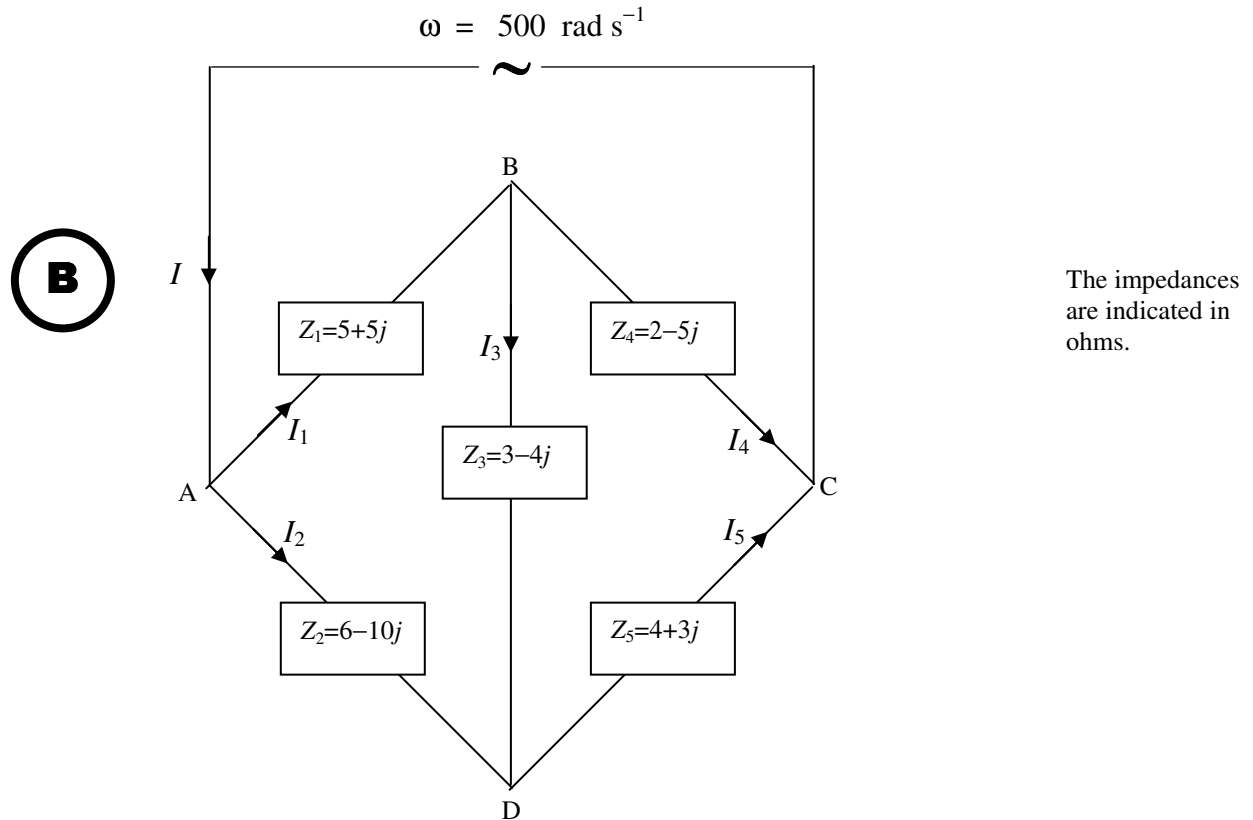

Our question is: What is the impedance of the circuit at a frequency of  $\omega = 500 \text{ rad s}^{-1}$ ?

We refer now to Chapter 4, Section 12. We are going to replace the left hand “delta” with its equivalent “star”. Recall equations 4.12.2 - 4.12.13. With alternating currents, We can use the same equations with alternating currents, provided that we replace the  $R_1R_2R_3G_1G_2G_3$  in the delta and the  $r_1r_2r_3g_1g_2g_3$  in the star with  $Z_1Z_2Z_3Y_1Y_2Y_3$  in the delta and  $z_1z_2z_3y_1y_2y_3$  in the star. That is, we replace the resistances with impedances, and conductances with admittances. This is going to need a little bit of calculation, and familiarity with complex numbers. I used a computer - hand calculation was too tedious and prone to mistakes. This is what I got, using  $z_1 = \frac{Z_2Z_3}{Z_1+Z_2+Z_3}$  and cyclic variations:

**C**

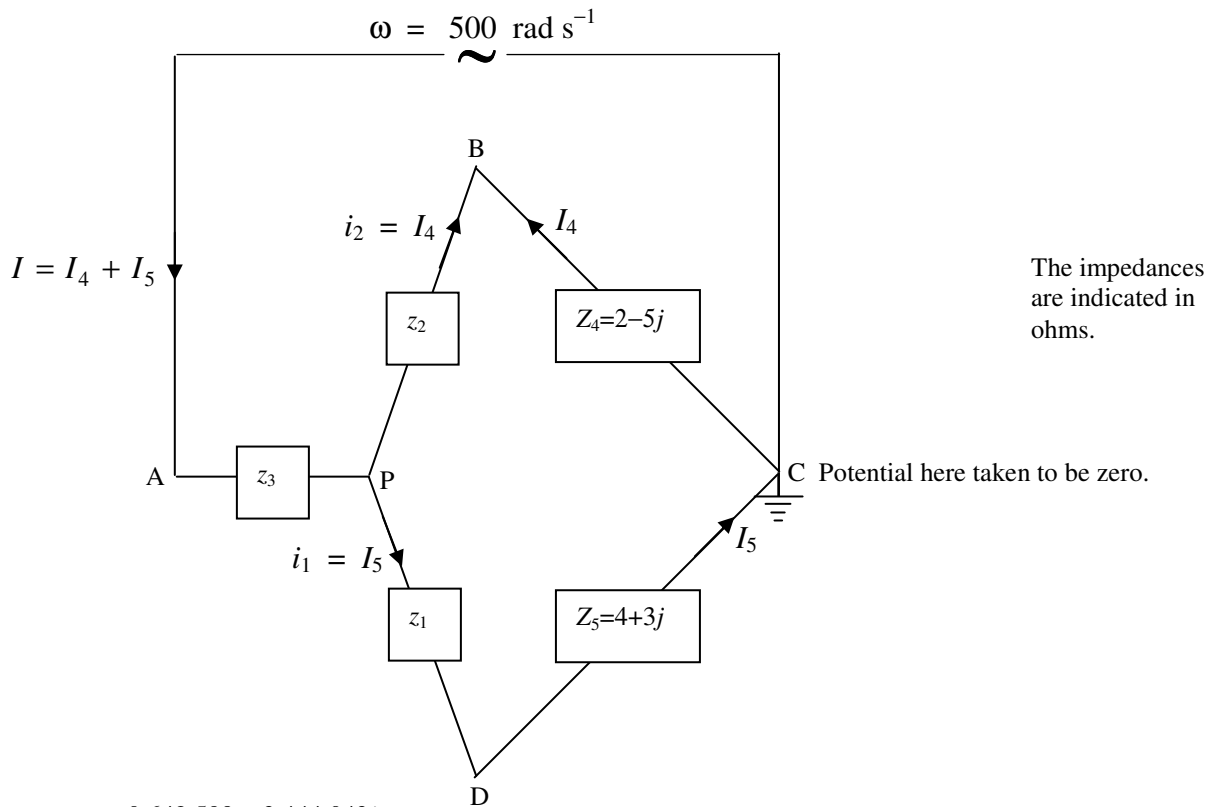

$$z_1 = 0.642\ 599 - 3.444\ 043j$$

$$z_2 = 1.931\ 408 + 0.884\ 477j$$

$$z_3 = 4.693\ 141 + 1.588\ 448j$$

The impedance of PBC is  $3.931\ 408 - 4.115\ 523j \ \Omega$ .

The impedance of PDC is  $4.642\ 599 - 0.444\ 043j \ \Omega$ .

The admittance of PBC is  $0.121\ 364 + 0.127\ 048j \ \text{S}$ .

The admittance of PDC is  $0.213\ 444 + 0.020\ 415j \ \text{S}$ .

The admittance of PC is  $0.334\ 808 + 0.147\ 463j \ \text{S}$ .

The impedance of PC is  $2.501\ 523 - 1.101\ 770j \ \Omega$ .

The impedance of AC is  $7.194\ 664 + 0.486\ 678j \ \Omega$ .

The admittance of AC is  $0.138\ 359 - 0.009\ 359j \ \text{S}$ .

Suppose the applied voltage is  $V = V_A - V_C = \hat{V} \cos \omega t$ , with  $\omega = 500 \text{ rad s}^{-1}$  and  $\hat{V} = 24 \text{ V}$ . Can we find the currents in each of  $Z_1, Z_2, Z_3, Z_4, Z_5$ , and the potential differences between the several points? This should be fun. I'm sitting in front of my computer. Among other things, I have trained it instantly to multiply two complex numbers and also to calculate the reciprocal of a complex number. If I ask it for  $(2.3 + 4.1j)(1.9 - 3.4j)$  it will instantly tell me  $18.31 - 0.03j$ . If I ask it for  $1/(0.5 + 1.2j)$  it will instantly tell me  $0.2959 - 0.7101j$ . I can instantaneously convert between impedance and admittance.

The current through any element depends on the *potential difference* across it. We can take any point to have zero potential, and determine the potentials at other points relative to that point. I choose to take the potential at C to be zero, and I have indicated this by means of a ground (earth) symbol at C. We are going to try to find the potentials at various other points relative to that at C.

In drawings **B** and **C** I have indicated the currents with arrows. Since the currents are alternating, they should, perhaps, be drawn as double-headed arrows. However, I have drawn them in the direction that I think they should be at some instant when the potential at A is greater than the potential at C. If any of my guesses are wrong, I'll get a negative answer in the usual way.

The total current  $I$  is  $V$  times the admittance of the circuit.

That is:  $I = 24 \times (0.138359 - 0.009359j) = \underline{\underline{(3.320611 - 0.224620j) \text{ A}}}$ .

The peak current will be  $3.328200 \text{ A}$  (because the modulus of the admittance is  $0.138675 \text{ S}$ ), and the current lags behind the voltage by  $3^\circ.9$ .

I hope the following two equations are obvious from drawing **C**.

$$\begin{aligned} I &= I_4 + I_5 \\ I_4(z_2 + Z_4) &= I_5(z_1 + Z_5) \end{aligned}$$

From this,

$$\begin{aligned} I_4 &= \left( \frac{z_1 + Z_5}{z_1 + z_2 + Z_4 + Z_5} \right) I = \left( \frac{4.642599 - 0.444043j}{8.574007 - 4.559567j} \right) \times (3.320611 - 0.224620j) \\ &= \underline{\underline{1.514284 + 0.511681j \text{ A}}} \end{aligned}$$

$I_4$  leads on  $V$  by  $18^\circ.7$      $\hat{I}_4 = 1.598397 \text{ A}$ .

$$I_5 = \left( \frac{z_2 + Z_4}{z_1 + z_2 + Z_4 + Z_5} \right) I = \underline{\underline{1.806328 - 0.736302j \text{ A}}}$$

$I_5$  lags behind  $V$  by  $22^\circ.2$      $\hat{I}_5 = 1.950631 \text{ A}$

Check:  $I_4 + I_5 = I$  ✓

I show below graphs of the potential difference between A and C ( $V = V_A - V_C$ ) and the currents  $I$ ,  $I_4$  and  $I_5$ . The origin for the horizontal scale is such that the potential at A is zero at  $t = 0$ . The vertical scale is in volts for  $V_C$ , and is five times the current in amps for the three currents.

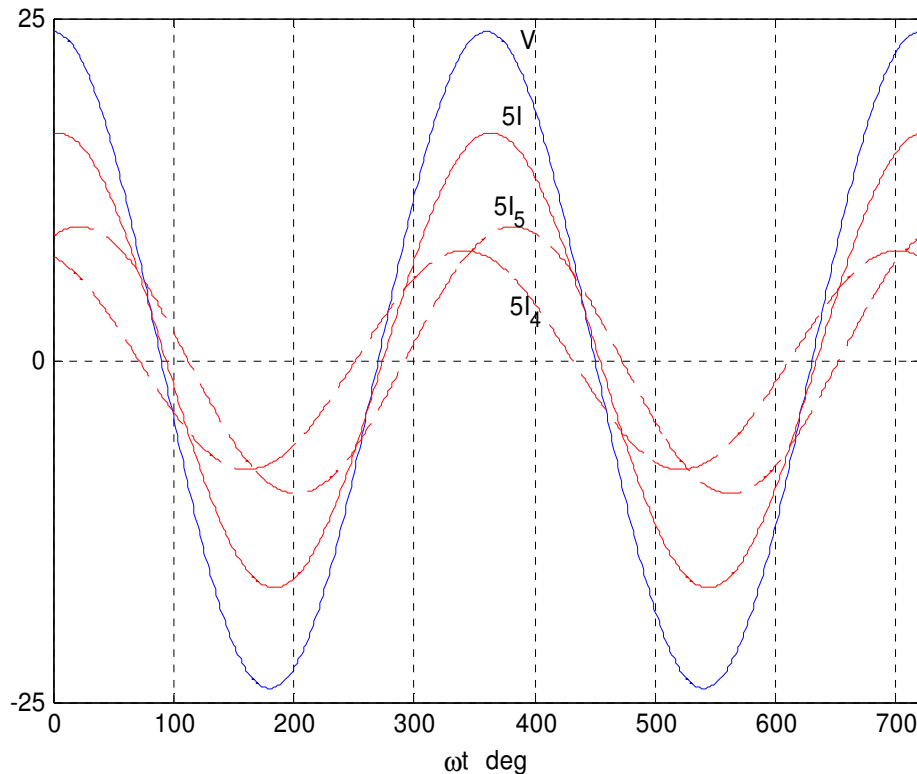

We don't really need to know  $i_1, i_2, i_3$ , but we do want to know  $I_1, I_2, I_3$ . Let's first see if we can find some potentials relative to the point C.

From drawing **C** we see that

$$V_B - V_C = V_B = I_4 Z_4, \text{ which results in } \underline{\underline{V_B = (5.586975 - 6.548057j) \text{ V}}}$$

$$V_B \text{ lags behind } V \text{ by } 0.864432 \text{ rad} = 49^\circ.5 \quad \hat{V}_B = 8.607603 \text{ V.}$$

From drawing **C** we see that

$$V_D - V_C = V_D = I_5 Z_5, \text{ which results in } \underline{\underline{V_D = (9.434216 + 2.473775j) \text{ V}}}$$

$$V_D \text{ leads on } V \text{ by } 0.256440 \text{ rad} = 14^\circ.7 \quad \hat{V}_D = 9.753153 \text{ V.}$$

We can now calculate  $I_3$  (see drawing **B**) from  $I_3 = \frac{V_B - V_D}{Z_3} = (V_B - V_D)Y_3$ . I find

$$\underline{\underline{I_3 = 0.981824 - 1.698178j \text{ A}}}$$

$$I_3 \text{ lags behind } V \text{ by } 1.046588 \text{ rad} = 60^\circ.0. \quad \hat{I}_3 = 1.961578 \text{ A.}$$

$I_1$  can now be found from  $I_1 = \frac{V_A - V_B}{Z_1} = (V_A - V_B)Y_1$ . The real part of  $V_A$  is 24 V, and (since we have grounded C), its imaginary part is zero. If in doubt about this verify that  $IZ = (3.320611 - 0.224620j)(7.194664 + 0.486678j) = (24 + 0j) \text{ V.} \checkmark$

I find

$$\underline{\underline{I_1 = 2.496108 - 1.186497j \text{ A}}}$$

$$I_1 \text{ lags behind } V \text{ by } 0.443725 \text{ rad} = 25^\circ.4. \quad \hat{I}_1 = 2.763753 \text{ A.}$$

In a similar manner, I find

$$\underline{\underline{I_2 = 0.824503 + 0.961876j \text{ A}}}$$

$$I_2 \text{ leads on } V \text{ by } 0.862147 \text{ rad} = 49^\circ.4. \quad \hat{I}_2 = 1.266891 \text{ A.}$$

Summary:

$$\underline{\underline{I = 3.320611 - 0.224620j \text{ A}}}$$

$$\underline{\underline{I_1 = 2.496108 - 1.186497j \text{ A}}}$$

$$\underline{\underline{I_2 = 0.824503 + 0.961876j \text{ A}}}$$

$$\underline{\underline{I_3 = 0.981824 - 1.698178j \text{ A}}}$$

$$\underline{\underline{I_4 = 1.514284 + 0.511681j \text{ A}}}$$

$$\underline{\underline{I_5 = 1.806328 - 0.736302j \text{ A}}}$$

These may be checked by verification of Kirchhoff's first rule at each of the points A, B, C, D.



Further remarks on the delta-star transform with alternating currents are given in Section 13.12

### 13.10 *The Transformer*

We met the transformer briefly in Section 10.9. There we pointed out that the EMF induced in the secondary coil is equal to the number of turns in the secondary coil times the rate of change of magnetic flux; and the flux is proportional to the EMF applied to the primary times the number of turns in the primary. Hence we deduced the well known relation

$$\frac{V_2}{V_1} = \frac{N_2}{N_1} \quad 13.10.1$$

relating the primary and secondary voltages to the number of turns in each. We now look at the transformer in more detail; in particular, we look at what happens when we connect the secondary coil to a circuit and take power from it.

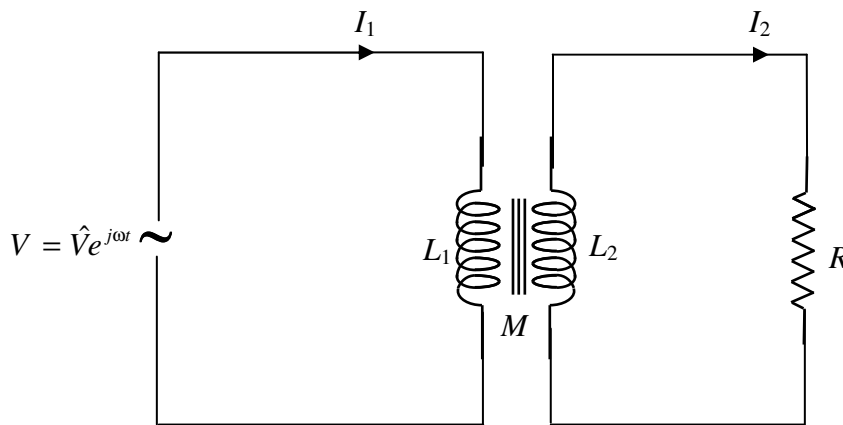

FIGURE XIII.12

In figure XIII.12, we apply an AC EMF  $V = \hat{V}e^{j\omega t}$  to the primary circuit. The self inductance of the primary coil is  $L_1$ , and an alternating current  $I_1$  flows in the primary circuit. The self inductance of the secondary coil is  $L_2$ , and the mutual inductance of the two coils is  $M$ . If the coupling between the two coils is very tight, then  $M = \sqrt{L_1 L_2}$ ; otherwise it is less than this. I am supposing that the resistance of the primary circuit is much smaller than the reactance, so I am going to neglect it.

The secondary coil is connected to a resistance  $R$ . An alternating current  $I_2$  flows in the secondary circuit.

Let us apply Ohm's law (or Kirchoff's second rule) to each of the two circuits.

In the *primary* circuit, the applied EMF  $V$  is opposed by two back EMF's:

$$V = L_1 \dot{I}_1 + M \dot{I}_2. \quad 13.10.2$$

That is to say 
$$V = j\omega L_1 I_1 + j\omega M I_2. \quad 13.10.3$$

Similarly for the *secondary* circuit:

$$0 = j\omega M I_1 + j\omega L_2 I_2 + R I_2. \quad 13.10.4$$

These are two simultaneous equations for the currents, and we can (with a small effort) solve them for  $I_1$  and  $I_2$ :

$$\left[ \frac{RL_1}{M} + j \left( \frac{\omega L_1 L_2}{M} - \omega M \right) \right] I_1 = \left( \frac{L_2}{M} - j \frac{R}{\omega M} \right) V \quad 13.10.5$$

and 
$$\left[ R + j \left( \omega L_2 - \frac{\omega M^2}{L_1} \right) \right] I_2 = -\frac{MV}{L_1}. \quad 13.10.6$$

This would be easier to understand if we were to do the necessary algebra to write these in the forms  $I_1 = (a + jb)V$  and  $I_2 = (c + jd)V$ . We could then easily see the phase relationships between the current and  $V$  as well as the peak values of the currents. There is no reason why we should not try this, but I am going to be a bit lazy before I do it, and I am going to assume that we have a well designed transformer in which the secondary coil is really tightly wound around the primary, and  $M = \sqrt{L_1 L_2}$ . If you wish, you may carry on with a less efficient transformer, with  $M = k\sqrt{L_1 L_2}$ , where  $k$  is a coupling coefficient less than 1, but I'm going to stick with  $M = \sqrt{L_1 L_2}$ . In that case, equations 13.10.5 and 6 eventually take the forms

$$I_1 = \left( \frac{L_2}{L_1 R} - j \frac{1}{L_1 \omega} \right) V = \left( \frac{N_2^2}{N_1^2 R} - j \frac{1}{L_1 \omega} \right) V \quad 13.10.7$$

and 
$$I_2 = -\frac{1}{R} \sqrt{\frac{L_2}{L_1}} V = -\frac{N_2}{N_1 R} V. \quad 13.10.8$$

These equations will tell us, on examination, the magnitudes of the currents, and their phases relative to  $V$ .

Now look at the circuit shown in figure XIII.13.

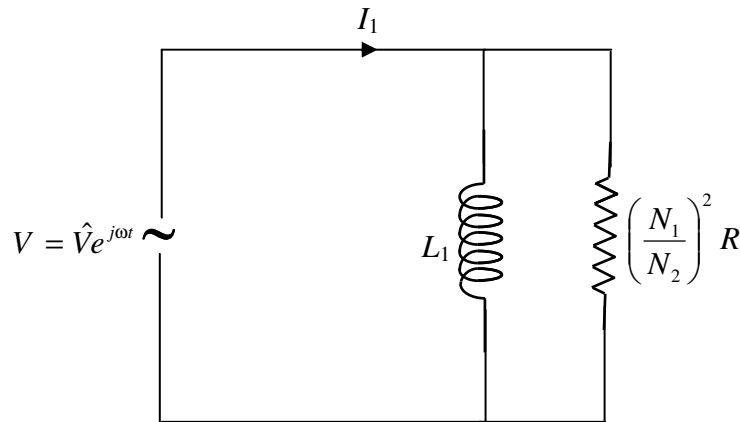

FIGURE XIII.13

In figure XIII.13 we have a resistance  $R(N_1/N_2)^2$  in parallel with an inductance  $L_1$ . The admittances of these two elements are, respectively,  $(N_2/N_1)^2/R$  and  $-j/(L_1\omega)$ , so the total admittance is  $\frac{N_2^2}{N_1^2 R} - j\frac{1}{L_1\omega}$ . Thus, as far as the relationship between current and voltage is concerned, the primary circuit of the transformer is precisely equivalent to the circuit drawn in figure XIII.13. To see the relationship between  $I_1$  and  $V$ , we need look no further than figure XIII.13.

Likewise, equation 13.10.8 shows us that the relationship between  $I_2$  and  $V$  is exactly as if we had an AC generator of EMF  $N_2V/N_1$  connected across  $R$ , as in figure XIII.14.

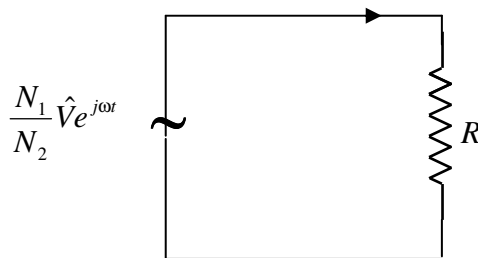

FIGURE XIII.14

Note that, if the secondary is short-circuited (i.e. if  $R = 0$  and if the resistance of the secondary coil is literally zero) both the primary and secondary current become infinite. If the secondary circuit is left open (i.e.  $R = \infty$ ), the secondary current is zero (as expected), and the primary current, also as expected, is not zero but is  $-jV/(L_1\omega)$ ; That is to say, the current is of magnitude  $V/(L_1\omega)$  and it lags behind the voltage by  $90^\circ$ , just as if the secondary circuit were not there.

### 13.11 Root-mean-square values, power and impedance matching

We have been dealing with alternating currents of the form  $I = \hat{I}e^{j\omega t}$ . I have been using the notation  $\hat{I}$  to denote the “peak” (i.e. maximum) value of the current. Of course, in the notation of complex numbers, this is synonymous with the *modulus* of  $I$ . That is to say  $\hat{I} = \text{mod } I = |I|$ . I shall use one or other notation wherever it is convenient. This will often mean using  $\hat{\phantom{x}}$  when describing time-varying quantities, and  $| \phantom{x} |$  when describing constant (but perhaps frequency dependent) quantities, such as impedances.

Suppose we have a current that varies with time as  $I = \hat{I} \sin \omega t$ . During a complete period ( $P = 2\pi / \omega$ ) the average or mean current is zero. The mean of the square of the current, however, is not zero. The mean square current,  $\overline{I^2}$ , is defined such that

$$\overline{I^2} P = \int_0^P I^2 dt. \quad 13.11.1$$

With  $I = \hat{I} \sin \omega t$ , this gives  $\overline{I^2} = \frac{1}{2} \hat{I}^2$ . The square root of this is the root-mean-square current, or the RMS value of the current:

$$I_{\text{RMS}} = \frac{1}{\sqrt{2}} \hat{I} = 0.707 \hat{I}. \quad 13.11.2$$

When we are told that an alternating current is so many amps, or an alternating voltage is so many volts, it is usually the RMS value that is meant, though we cannot be sure of this unless the speaker or writer explicitly says so. If you wish to be understood and not misunderstood in your own writings, you will always make it explicitly clear what meaning you intend.

If an alternating current is flowing through a resistor, at some instant when the current is  $I$ , the instantaneous rate of dissipation of energy in the resistor is  $I^2 R$ . The mean rate of dissipation of energy during a complete cycle is  $I_{\text{RMS}}^2 R$ . This is one obvious reason why the concept of RMS current is important.

Now cast your mind back to Chapter 4, Section 4.8. There we imagined that we connected a resistance  $R$  across a battery of EMF  $E$  and internal resistance  $r$ . We calculated that the power delivered to the resistance was  $P = I^2 R = \frac{E^2 R}{(R + r)^2}$ , and that this was greatest (and equal to  $\frac{1}{4} E^2 / r$ ), when the external resistance was equal to the internal resistance of the battery.

What is the corresponding situation with alternating current? Suppose we have a box (a “source”) that delivers an alternating voltage  $V$  (which is represented by a complex number  $\hat{V}e^{j\omega t}$ ), and that this box has an internal impedance  $z = r + jx$ . If we connect across the box a device (a “load”) that has an impedance  $Z = R + jX$ , what will be the power delivered to the load, and can we match the external impedance of the load to the internal impedance of the box in such a manner that the power delivered to the load is greatest?

The second question is quite easy to answer. Reactance can be either positive (inductive) or negative (capacitive), and so it is quite possible for the total reactance of the entire circuit to be zero. Thus for a start, we want to ensure that  $X = -x$ . That is, the external reactance should be equal in magnitude but opposite in sign to the internal reactance. The circuit is then purely resistive, and the power delivered to the circuit is just what it was in the direct current case, namely

$P = I^2 R = \frac{E^2 R}{(R + r)^2}$ , where the current and EMF in this equation are now RMS values. And, as in the direct current case, this is greatest if  $R = r$ . The conclusion is that, for maximum power transfer,  $R + jX$  should equal  $r - jx$ . That is, for the external and internal impedances to be matched for maximum power transfer,  $Z = z^*$ . The load impedance should equal the conjugate of the source impedance.

What is the power delivered to the load when the impedances are not matched? In other words, when  $z = r + jx$  and  $Z = R + jX$ . It is  $P = \frac{1}{2} \hat{I}^2 R$ . The current is given by the equation  $E = I(Z + z)$ . (These are all complex numbers - i.e. they are all periodic functions with different phases.  $E$  and  $I$  vary with time.) Now if  $w_1$  and  $w_2$  are two complex numbers, it is well known (from courses in complex numbers) that  $|w_1 w_2| = |w_1| |w_2|$ . We apply this now to  $E = I(Z + z)$ . [I shall use  $\hat{\phantom{x}}$  for the “peak” of the time-varying quantities, and  $|\phantom{x}|$  for the modulus of the impedances] We obtain  $\hat{E} = \hat{I} |Z + z|$ .

$$\text{Thus } P = \frac{1}{2} \hat{I}^2 R = \frac{1}{2} \frac{\hat{E}^2 R}{|Z + z|^2} = \frac{E_{\text{RMS}}^2 R}{\underline{\underline{(R + r) + (X + x)^2}}} \quad 13.11.3$$

### 13.12 Some Remarks on the Star-Delta Transform

We pointed out in Section 13.9.4 that we can use the star-delta transform with alternating currents, provided that we replace the several  $R, G, r, g$  quantities in equations 4.12.1 - 4.12.13 with the corresponding  $Z, Y, z, y$  quantities of alternating current theory. Because  $Z, Y, z, y$  are all complex, the calculation of the transforms may be tedious, and it requires care and patience even though it is in principle straightforward. The calculation is eased somewhat by understanding that if two complex numbers are equal, their real and imaginary parts are separately equal, and by remembering what to do if a complex number appears in the denominator of an expression. We successfully performed such a calculation in Section 13.9.4.

A warning may be in order. It may sometimes happen that, in applying the delta-star transform to a circuit with an alternating current, in the transformed geometry the real part of the impedance of an arm (i.e. the resistance) turns out to be negative. This may be disconcerting when first encountered. Nevertheless, even in such cases, the delta-star transform may still be a useful computational device in solving a circuit problem, even though the transformed circuit is a physical impossibility.

A negative didn't happen in our example in Section 13.9.4, but here's a simple example where it does happen. What is the equivalent delta of the star shown below, assuming that the angular frequency of the current is  $\omega = 2 \times 10^4 \text{ rad s}^{-1}$  (frequency  $\nu = 10^4/\pi \text{ Hz}$ )?

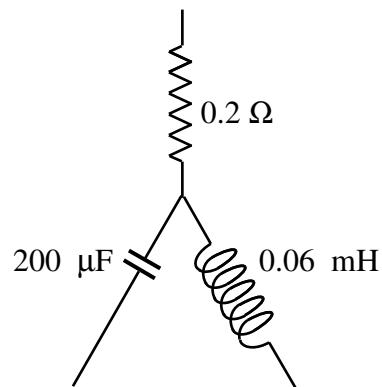

FIGURE XIII.15

Let's relabel the drawing showing the impedances in ohms.

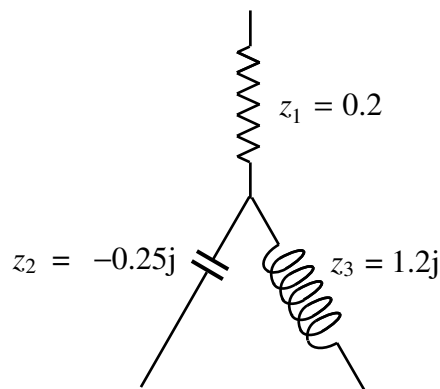

FIGURE XIII.16

Using the transforms  $Z_1 = \frac{z_2 z_3 + z_3 z_1 + z_1 z_2}{z_1}$ , etc., we find that the impedances of the sides of the delta, in ohms, are:  $Z_1 = 1.50 + 0.95j$

$$Z_2 = -0.76 + 1.20j$$

$$Z_3 = 0.1583 - 0.25j$$

Recall that inductive reactance is  $L\omega$  and capacitive reactance is  $-1/(C\omega)$ . With this in mind we see that:

We could represent  $Z_1$  as a resistance of  $1.50 \Omega$  in series with an inductance of  $0.0475 \text{ mH}$ .

We could represent  $Z_2$  as a resistance of  $-0.76 \Omega$  in series with an inductance of  $0.06 \text{ mH}$ .

We could represent  $Z_3$  as a resistance of  $0.1583 \Omega$  in series with a capacitance of  $200 \mu\text{F}$ ,

In a typical problem we may be given the elements of a star, and, for a given frequency, be asked to determine the elements of the corresponding delta, or *vice versa*. However, since the reactance of every element is frequency-dependent, this gives the opportunity of devising a problem in which the resistances, capacitances and inductances are given in all arms of both the star and the corresponding delta, and asking what the frequency must be.

For example, suppose the star has

First arm: A resistance of  $0.2 \Omega$

Second arm: A capacitance of  $200 \mu\text{F}$

Third arm: An inductance of  $0.06 \text{ mH}$

and the corresponding delta has

First side: A resistance of  $1.50 \Omega$  in series with an inductance of  $0.0475 \text{ mH}$

Second side: A resistance of  $-0.76 \Omega$  in series with an inductance of  $0.06 \text{ mH}$

Third side: A resistance of  $0.1583 \Omega$  in series with a capacitance of  $200 \mu\text{F}$ .

What is the frequency?

The impedances in ohms are:

In the star

$$z_1 = 0.2$$

$$z_2 = -5000j/\omega$$

$$z_3 = 6 \times 10^{-5} j\omega$$

In the delta:

$$Z_1 = 1.50 + 4.75 \times 10^{-5} j\omega$$

$$Z_2 = -0.76 + 6 \times 10^{-5} j\omega$$

$$Z_3 = 0.1583 - 5000j/\omega$$

If we now use  $Z_1 = \frac{z_2 z_3 + z_3 z_1 + z_1 z_2}{z_1}$  we find, with some care, that  $\omega = 2 \times 10^4 \text{ rad s}^{-1}$

If one were to start with the elements of the delta and the corresponding star in Section 13.9.4, one could presumably recover the angular frequency of  $500 \text{ rad s}^{-1}$ . I don't think I can summon up the energy myself.

### 13.13 *The Telephonist's, or Telegrapher's, Equations*

How fast does “electricity” travel down a wire? I think at one time in my life, I imagined that somehow electrons in a metal wire were racing around the circuit at the speed of light, or, in an alternating current, they were rushing to and fro at such a speed. We know of course that the real situation is nothing like that at all. We saw, for example, in Chapter 4, Section 4.3, that in a direct current in a wire, the drift of electrons along a wire is very, very slow indeed, while in an alternating current the electrons presumably hardly move at all. And yet, when we close the switch in an electrical circuit, something seems to happen almost instantaneously. Some sort of electrical signal must travel down the wire at great speed.

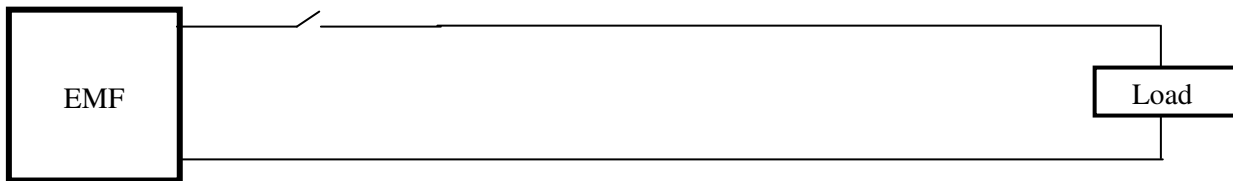

FIGURE XIII.17

In figure XIII.17, the box EMF is some sort of device that provides an electromotive force. It may be just a battery that provides a constant EMF, or it may be a generator that provides something like  $E = \hat{E} \cos \omega t$ . It doesn't matter much what the “Load” is at the right. I am just interested in what happens in the cable connecting them when we close the switch.

By the “cable” I mean both the outgoing and the returning wire together. I have drawn the outgoing and returning wires of the cable as if they are well separated. In practice they may be very close together. For example, they could be twisted around each other in a DNA-like double helix. Or the cable could be a coaxial cable. In the former case the cable may have a considerable inductance per unit length. In the latter case it may have a considerable capacitance per unit length. Another possibility is that, with the wires close together, there may be a small leak of electricity between the outgoing and returning wires of the cable.

When we close the switch, a length  $\delta x$  of the cable presents some sort of impedance to the flow of electricity which is equivalent to the circuit shown below in figure XIII.18



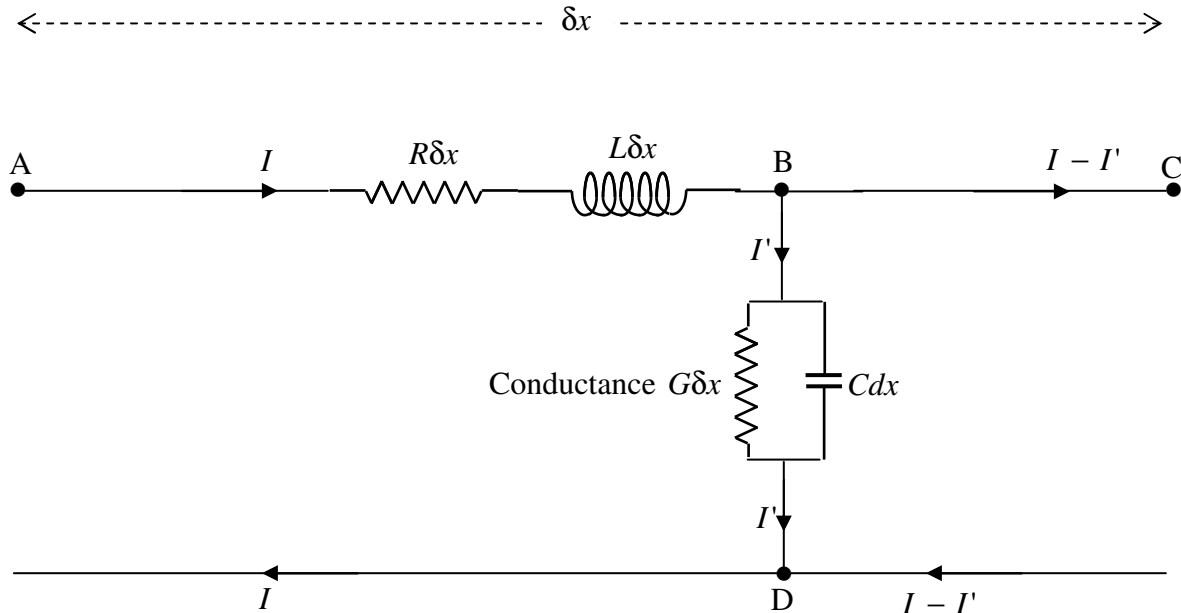

FIGURE XIII.18

In the figure,  $R$  represents the resistance per unit length ( $\Omega \text{ m}^{-1}$ ) of the *cable*. This includes the resistance of the outgoing and the returning wires; since they are in series I combine them as a single resistance  $R\delta x$ . Likewise  $L$  represents the inductance per unit length ( $\text{H m}^{-1}$ ) of the *cable*. This includes the self inductances of the two wires as well as the mutual inductance between them.  $C$  represents the capacitance per unit length ( $\text{F m}^{-1}$ ) of the cable, and  $G$  represents the conductance per unit length ( $\text{S m}^{-1}$ ) of the insulation between the wires.

The potential along the circuit and the current through it are both functions of  $x$  and of  $t$ . We can take the potential to be zero at any arbitrary point. I choose to take the point D to have zero potential,

At some instant, when the current (which is the same in both wires) is  $I$  and its rate of change is  $\dot{I}$ , the potential drop from A to B is  $IR\delta x + \dot{I}L\delta x$ . (Carefully note the signs.) Thus the potential gradient down the wire is given by

$$\frac{\partial V}{\partial x} = -IR - L\frac{\partial I}{\partial t}. \quad 13.13.1$$

Likewise the current at C is less than the current at A by  $VG\delta x + \dot{V}C\delta x$ . [ $V$  is the potential difference between B and D, or the potential at B, since we are taking the potential at D to be zero.

The term  $VG\delta x$  is just Ohm's Law. The term  $\dot{V}C\delta x$  is the rate at which the capacitor (of capacitance  $C\delta x$ ) is accumulating charge.] Thus the current gradient down the wire is

$$\frac{\partial I}{\partial x} = -GV - C \frac{\partial V}{\partial t}. \quad 13.13.2$$

Differentiate equation 13.13.1 with respect to  $x$  and equation 13.13.2 with respect to  $t$  and eliminate the mixed partial second derivatives to obtain

$$\frac{\partial^2 V}{\partial x^2} - LC \frac{\partial^2 V}{\partial t^2} - (RC + LG) \frac{\partial V}{\partial t} - RGV = 0. \quad 13.13.3$$

By differentiating equation 13.13.1 with respect to  $t$  and equation 13.13.2 with respect to  $x$ , one obtains a similar equation in the current:

$$\frac{\partial^2 I}{\partial x^2} - LC \frac{\partial^2 I}{\partial t^2} - (RC + LG) \frac{\partial I}{\partial t} - RGI = 0. \quad 13.13.4$$

Any of the equations 13.13.1-4 are referred to as the “telephonist's” or the “telegrapher's” equations, and they tell you how the potential and current vary down the wire in space and in time..

The solutions of these equations, which will depend on the relative sizes of the elements in the equation and on the initial conditions, are best left to those who have taken courses in partial differential equations more recently than I. I can say that there will be two parts to the solution. There will be a transient solution that dies out either slowly (if  $R$  and  $C$  are large and  $L$  is small) or rapidly (if otherwise). Although the transient is only ephemeral, the maximum current during the brief period may be quite high, and it is often during the transient phase that a fuse will blow. You have often noticed that a fuse blows at the moment when you switch on. After the transient has died down, there will remain a steady-state solution. If the EMF is from a battery, the steady-state solution will, of course, be a steady current. If the EMF is sinusoidal, so will the steady state solution be.

There is an easy solution in the case where the resistance per unit length of the wire, and the conductance of the insulation separating the outgoing and returning wires, are small. At this point you will be (or ought to be) asking: “Small? Small compared with what?” So let's say  $R$  is small compared with  $\sqrt{L/C}$ , and  $G$  is small compared with  $\sqrt{C/L}$ .  $\sqrt{L/C}$  has the same dimensions as resistance, and is known as the *characteristic impedance* of the line. If we put  $R$  and  $G$  equal to zero in equation 13.3.1, so that we have an ideal lossless cable, and the transmission of the potential is governed by its inductance and capacitance per unit length alone, the equation becomes simply

$$\frac{\partial^2 V}{\partial x^2} = LC \frac{\partial^2 V}{\partial t^2}, \quad 13.13.5$$

and we see that the signal is transmitted down the wire at a speed of  $\frac{1}{\sqrt{LC}}$ . Typical order-of-magnitude values for a telephone cable might be about  $C = 5 \times 10^{-11} \text{ F m}^{-1}$ , and  $L = 5 \times 10^{-7} \text{ H m}^{-1}$ , giving a speed of about  $2 \times 10^8 \text{ m s}^{-1}$  or about  $\frac{2}{3}$  of the speed of light *in vacuo*.